

**Simple Resistive Protection**

When a high voltage is transmitted via a coaxial cable -such as the cable supplied with Lambda EMIs ALE HV Capacitor Charging Supplies- it should be terminated in a resistance equal to or greater than the cable characteristic impedance. The resistor limits reflected energy from the shorted cable from reaching supply output stages. This reverse voltage can cause erratic operation, and potentially actual damage to the output section of the power supply. The sketch in figure 1 below shows a typical HV capacitor charging supply load connection.

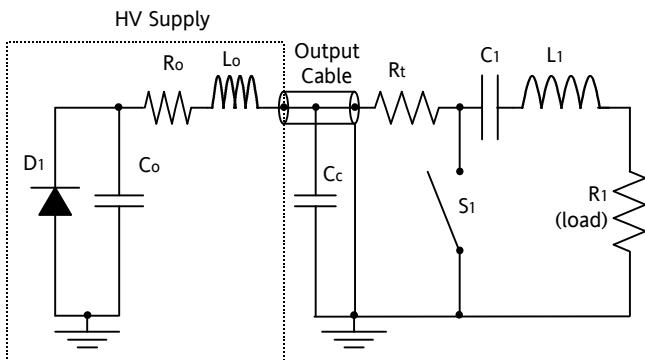

Figure 1. Generalized HV Supply Load Connection

If Rt is not in the circuit, when the switch S1 closes the supply output cable (which is a short PFN) is discharged through S1 along with the energy from C1. The pulse produced by discharging the output cable is inverted and reflected at the shorted switch S1 and propagates back into the HV Supply output stages. The addition of Rt to the circuit presents a matched load to the supply output cable impedance, and hence the pulse produced when S1 is closed is dissipated in Rt.

The value of Rt is typically 50 to 500Ω with a power rating of 200W. This rating ensures enough physical size to provide sufficient voltage holdoff capability during the discharge period. For example, the power rating of the terminating resistor for a series 303 supply @ 40kV can be calculated as follows:

$I_{out} = 1.88A, R_t = 50\Omega$   
Average power is =  $1.88 \times 50 = 176$  Watts

There are two additional sources of current that can cause the dissipated power to increase by several orders of magnitude. The first source is the distributed energy stored in the supply output cable capacitance Cc. With reference to figure 1, the internal capacitance of the supply Co along with Cc is discharged through Rt and Ro (Ro represents the supply output resistance which is typically a few ohms or less) every time S1 closes.

A typical value for Co is 200pF, and Cc is related to the length of output cable (~30pF/ft) which could be 300pF for a standard 10ft cable.

Assuming a circuit charge voltage of 40kV the stored energy in Co and Cc can simply be calculated using the following equation;

$E = \frac{1}{2}CV^2 = \frac{1}{2} \times (500pF) \times (40kV)^2 = 0.4$  Joules

If the discharge circuit is operating at a repetition rate (rep. rate) of 1kHz, then the mean power dissipated in Rt and Ro is 0.4 Joules x 1000 or 400W.

Additional power dissipation in Rt is caused by voltage reversal across S1. For example in a positive output power supply, if the discharge circuit is underdamped when switch S1 closes the voltage on the HV cable will undershoot and a transient negative voltage is applied to the supply output stage. When this occurs current will flow out of the power supply through the now forward biased output rectifiers and Rt to ground. This is illustrated in Figure 2 below.

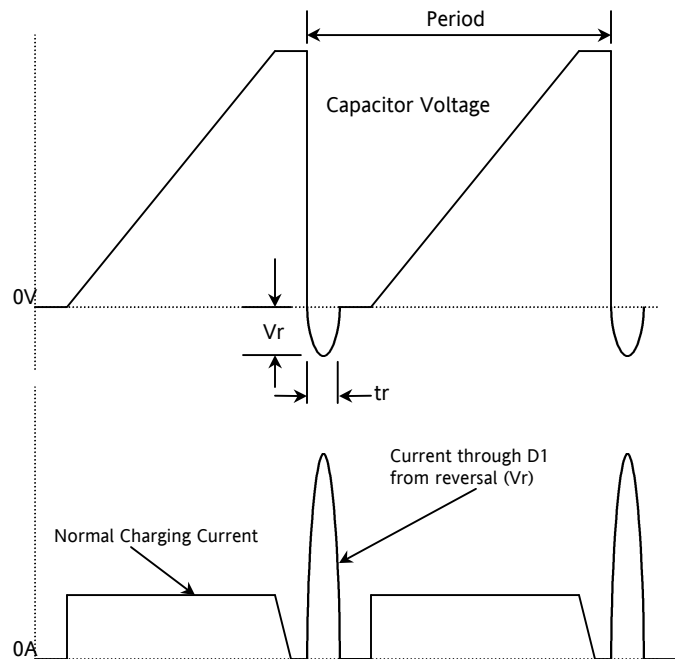

Figure 2. HV Supply output diode current under voltage reversal conditions.

If the peak current associated with load voltage reversal is large enough, damage to the output rectifiers may occur. The damage threshold for voltage reversal is difficult to quantify but if a reversal causes the output current to be greater than the supply rated output current then a protection diode should be added to the load circuit.

The following formula can be used as a guide when deciding whether or not to include a reverse protection diode.

Diode required if;  $\frac{V_r}{R_t} \geq I_{rated}$

Where; Vr is the voltage reversal in volts,  
I<sub>rated</sub> is rated output current of the HV supply  
Rt is series resistance shown in Figure 1

**Diode Resistor Protection**

A typical load circuit with an additional protection diode is shown in Figure 3 below.

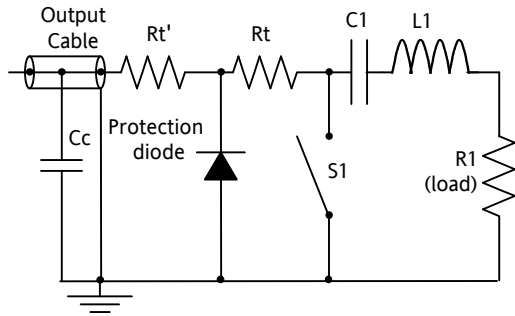

Figure 3. Voltage Reversal Protection Circuit

The choice of bypass diode is very important to achieve reliable and effective reversal protection. The user must ensure that the following three diode ratings are sufficient for the application.

*The diode reverse voltage rating must be greater than the circuit operating voltage, and the supply operating voltage.*

*The diode RMS. current is less than the manufacturers rated figure.*

*The forward voltage drop across the diode during conduction should be less than the voltage drop across the diodes in the supply if Rt' is not used.*

For safety sake the user should factor the rated voltage by approx. 1.5 to give a margin if any overvoltage transients are present in the load circuit. In the case of a 20kV supply the reverse protection diode should be rated at approximately 30kV.

The protection diode RMS. current rating must be greater than the current due to load voltage reversals. The RMS. rating can be determined using the following steps.

Peak current during voltage reversal is determined from;

$$I_{pk} = \frac{V_r}{R_t}$$

Where Rt is the resistor shown in the circuit of figure 3. For pulse reversal the RMS. current during a single cycle is;

$$I_{rms} \text{ (pulse)} = \frac{I_{pk}}{\sqrt{2}}$$

With repetitive load operation the overall RMS. current in the protection diode can be determined from RMS. current for a single cycle and the duty cycle of the reversal event, as below;

$$I_{rms} = I_{rms} \text{ (pulse)} \times \sqrt{\text{duty cycle}}$$

Information cannot be guaranteed and may be subject to change without notice.

Vr can be measured on a scope using an HV probe. Start with the power supply set to a low output voltage without a bypass diode for the first measurements and calculate the percent reversal. Use this as a guide as what to expect at full voltage, thus avoiding operation at full voltage without a bypass diode.

The forward voltage drop across the protection diode is critical in achieving effective supply protection. The circuit in figure 4 below shows the equivalent supply output circuit with a voltage reversal.

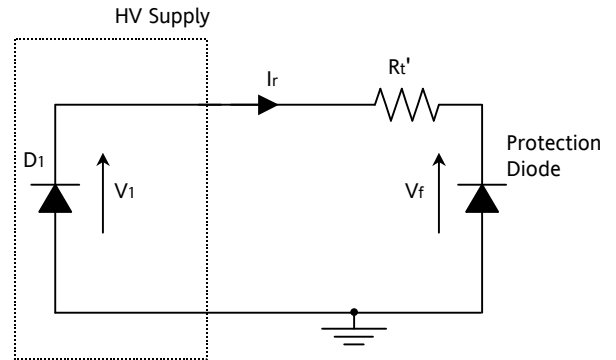

Figure 4. Supply equivalent output circuit with reverse protection diode shown.

The reverse current Ir is given from;

$$I_r = \frac{V_f - V_1}{R_{t'}}$$

The resistance of Rt' should be selected to maintain Ir to a figure less than or equal to the supply rated output current. The key figure in selecting the protection diode is to ensure that Vf is as low as possible.

The critical parameters which should be considered when selecting the reverse protection diode are;

- Reverse Voltage Rating** - Should be greater than supply operating voltage.
- RMS. Current Rating** - should be greater than Irms due to load voltage reversal.
- Forward Voltage Drop** - as small as possible.

Note: The recovery time of the voltage reversal protection diode does not have to be fast.

Potential suppliers of reverse protection diodes are;

Semtech - 652 Mitchell Rd, Newbury Park, CA. 91320 USA. Tel. 800-298-2111, 805-498-2111

CKE - P.O. Box 211, Lucernemines, PA. 15754 USA. Tel. 724-479-3533. Web: www.cke.com

VMI - 8711 W. Roosevelt Ave, Visalia, CA. 93291. Tel. 209-651-1402. Web: www.voltagemultipliers.com